

Before beginning any service procedure, refer to section S of the 1996 626/MX-6 Body Electrical Troubleshooting Manual for air bag system service warnings.

LUBRICATION SYSTEM

(KL)

D2

INDEX	D2- 2
OUTLINE	D2- 3
SPECIFICATIONS	D2- 3
TROUBLESHOOTING GUIDE	D2- 3
OIL PRESSURE	D2- 4
PREPARATION	D2- 4
INSPECTION	D2- 4
ENGINE OIL	D2- 5
INSPECTION	D2- 5
REPLACEMENT	D2- 5
OIL FILTER	D2- 6
PREPARATION	D2- 6
REPLACEMENT	D2- 6
OIL COOLER	D2- 7
PREPARATION	D2- 7
REMOVAL / INSTALLATION	D2- 7
OIL PAN	D2- 8
REMOVAL / INSTALLATION	D2- 8
INSPECTION	D2- 9
OIL PUMP	D2-11
PREPARATION	D2-11
DISASSEMBLY / ASSEMBLY	D2-11
INSPECTION	D2-12

INDEX

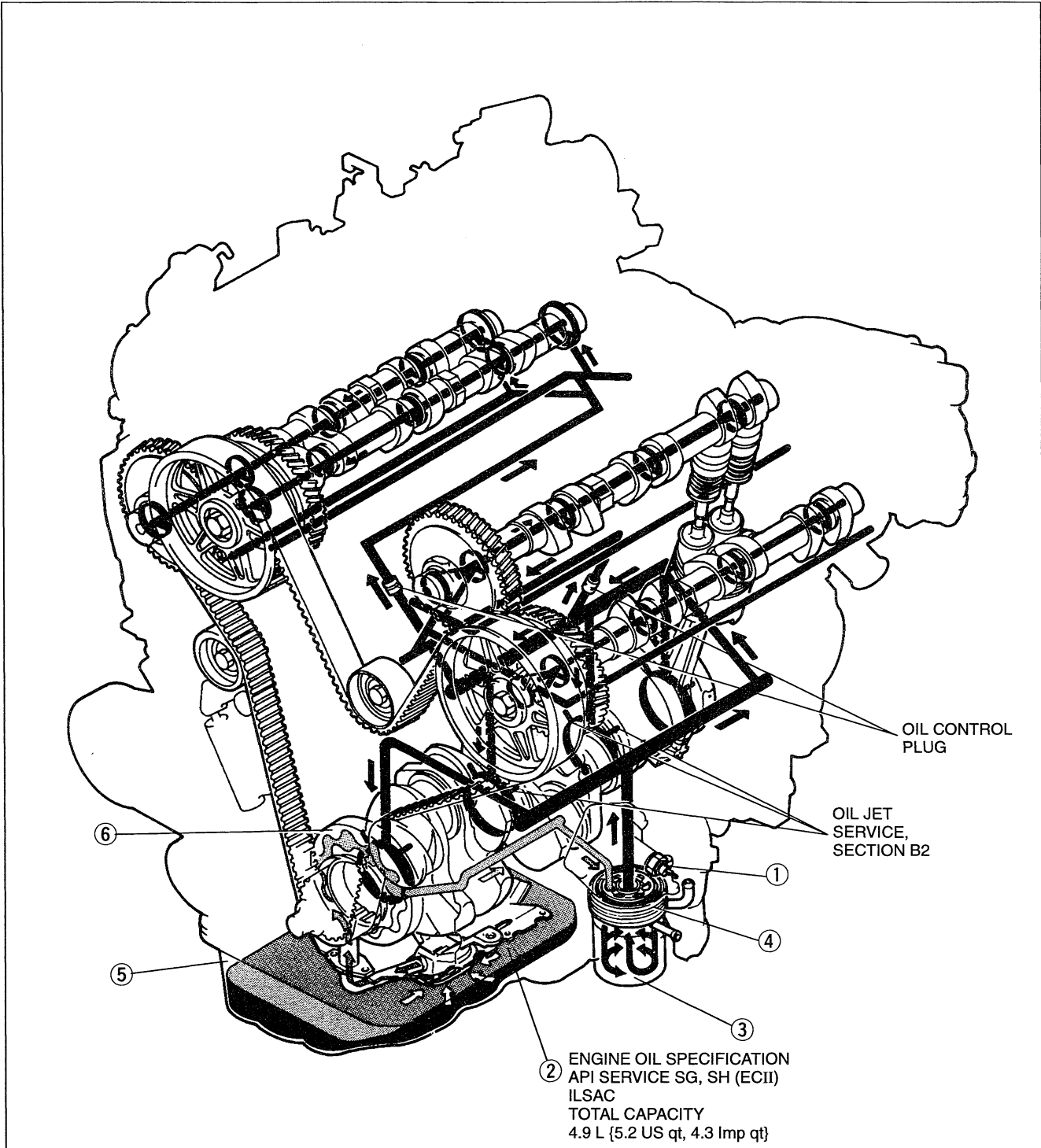

- 1. Oil pressure
Inspection page D2-4
- 2. Engine oil
Inspection page D2-5
Replacement page D2-5
- 3. Oil filter
Replacement page D2-6
- 4. Oil cooler
Removal / Installation page D2-7

- 5. Oil pan
Removal / Installation page D2- 8
Inspection page D2- 9
- 6. Oil pump
Disassembly / Assembly page D2-11
Inspection page D2-12

OUTLINE

SPECIFICATIONS

Item		Engine	KL
Lubrication system			Force-fed type
Oil pump	Type		Trochoid gear
	Relief pressure	kPa {kgf/cm ² , psi}	491—588 {5.0—6.0, 72—85}
Oil filter	Type		Full-flow, paper element
	By-pass pressure differential	kPa {kgf/cm ² , psi}	79—117 {0.8—1.2, 12—17}
Oil capacity	Total (dry engine)	L {US qt, Imp qt}	4.9 {5.2, 4.3}
	Engine oil replacement	L {US qt, Imp qt}	3.7 {3.9, 3.3}
	Engine oil replacement (with oil filter)	L {US qt, Imp qt}	4.0 {4.2, 3.5}
Engine oil			API Service SG, SH (EC II) ILSAC

D2

Recommended SAE Viscosity

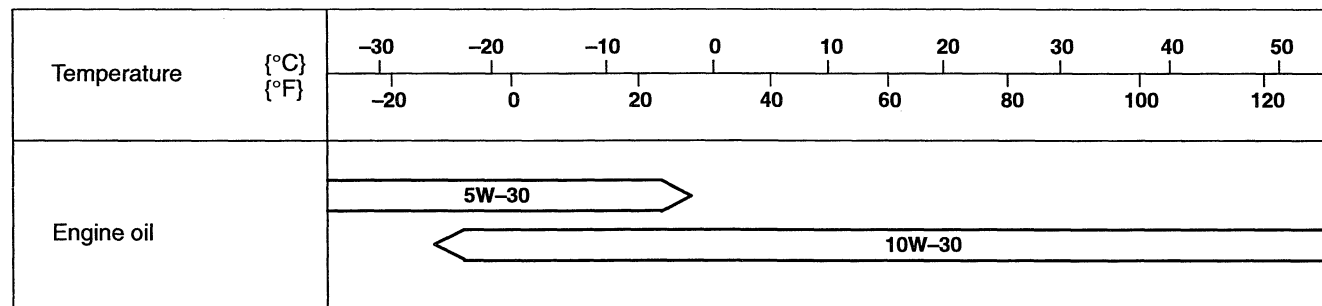

Anticipated ambient temperature range before succeeding oil change, °C {°F}

TROUBLESHOOTING GUIDE

Problem	Possible Cause	Remedy	Page
Engine hard starting	Improper engine oil	Replace	D2- 5
	Insufficient engine oil	Add oil	D2- 5
Excessive oil consumption	Oil working up or down in cylinder Oil leakage	Refer to section B2 Repair	—
Oil pressure drop	Insufficient engine oil	Add oil	D2- 5
	Oil leakage	Repair	—
	Worn and/or damaged oil pump rotor	Replace	D2-11
	Worn plunger (inside oil pump) or weak spring	Replace	D2-11
	Clogged oil strainer	Clean	—
	Excessive main bearing or connecting rod bearing clearance	Refer to section B2	—
Warning light illuminates while engine is running	Oil pressure drop Malfunction of oil pressure switch	As described above Refer to 1996 626/MX-6 Body Electrical Troubleshooting Manual	—
	Malfunction of electrical system	Refer to 1996 626/MX-6 Body Electrical Troubleshooting Manual	—

Warning

- Continuous exposure with USED engine oil has caused skin cancer in laboratory mice. Protect your skin by washing with soap and water immediately after this work.

OIL PRESSURE

PREPARATION

SST

<p>49 0187 280</p> <p>Gauge, oil pressure</p> 	<p>For inspection of oil pressure</p>
---	---------------------------------------

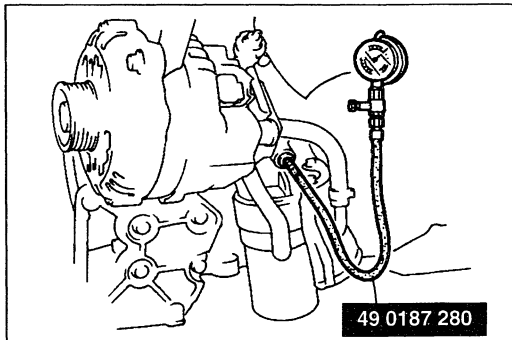
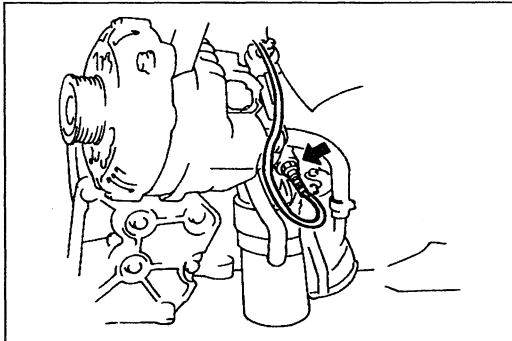

INSPECTION

1. Remove the oil pressure switch.

2. Screw the **SST** into the oil pressure switch installation hole.
3. Warm up the engine to normal operating temperature.
4. Run the engine at the specified speed, and note the gauge readings.

Note

- Oil pressure varies with oil viscosity and temperature.

Oil pressure: 334—490 kPa
{3.4—5.0 kgf/cm², 49—71 psi}—3,000 rpm

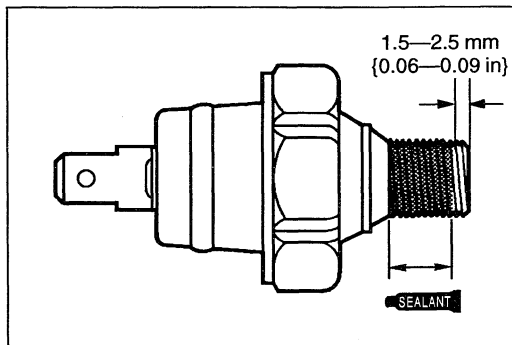

5. If the pressure is not as specified, check for the cause and repair as necessary. (Refer to Troubleshooting Guide, page D2-3.)
6. Apply silicone sealant to the oil pressure switch threads as shown.

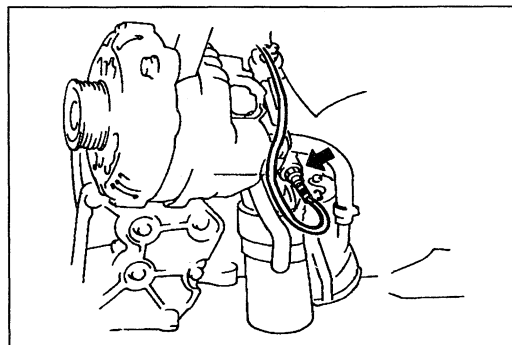

7. Remove the **SST** and install the oil pressure switch.

Tightening torque:

12—17 N·m {1.2—1.8 kgf·m, 8.7—13.0 ft·lbf}

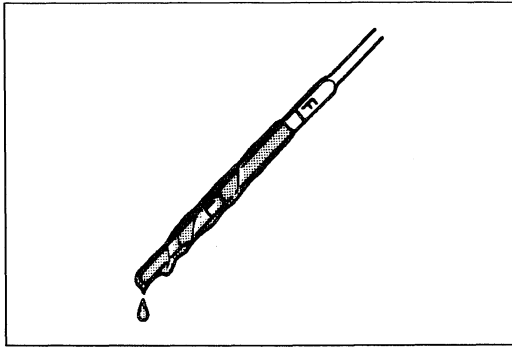

ENGINE OIL

INSPECTION

1. Be sure the vehicle is on level ground.
2. Warm up the engine to normal operating temperature and stop it.
3. Wait for five minutes.
4. Remove the dipstick and check the oil level and condition.
5. Add or replace oil as necessary.

D2

Note

- The distance between the L and F marks on the dipstick represents 1.0 L {1.1 US qt, 0.9 Imp qt}.

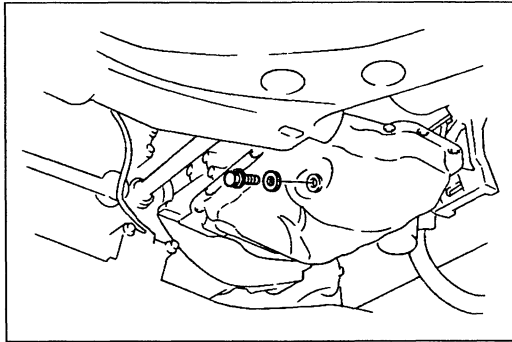

REPLACEMENT

Warning

- When the engine and the oil are hot, they can badly burn. Don't burn yourself with either.

1. Remove the oil filler cap and the oil pan drain plug.
2. Drain the oil into a container.
3. Install a new gasket and the drain plug.

Tightening torque:

30—41 N·m {3.0—4.2 kgf·m, 22—30 ft·lbf}

4. Refill the engine with the specified type and amount of engine oil.

Oil capacity

L {US qt, Imp qt}

Total (dry engine)	4.9 {5.2, 4.3}
Engine oil replacement	3.7 {3.9, 3.3}
Engine oil replacement (with oil filter)	4.0 {4.2, 3.5}

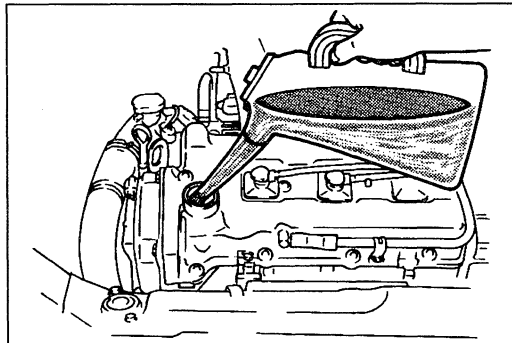

5. Refit the oil filler cap.
6. Run the engine and check for leaks.
7. Check the oil level and add oil if necessary.

OIL FILTER

PREPARATION
SST

49 G014 001		For removal / installation of oil filter
Wrench, oil filter		

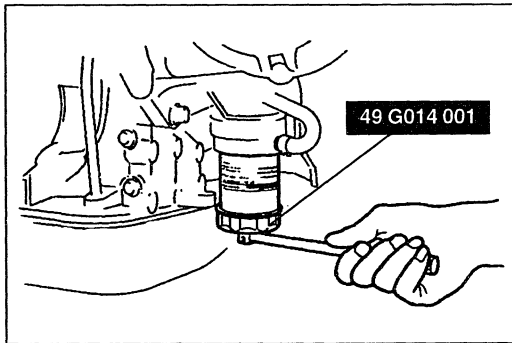
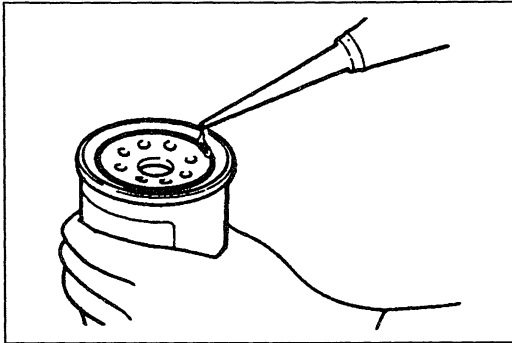
**REPLACEMENT**

1. Remove the oil filter by using the **SST**.
2. Use a clean rag to wipe off the mounting surface on the oil cooler base.
3. Apply clean engine oil to the O-ring of the new filter.
4. Install the oil filter and tighten it by hand until the O-ring contacts the oil cooler base.
5. Tighten the filter 1 and 1/6 turns by using the **SST**.

Tightening torque:

14—17 N·m {1.4—1.8 kgf·m, 11—13 ft·lbf}

6. Start the engine and check for leaks.
7. Check the oil level and add oil if necessary.

Oil filter capacity: 0.3 L {0.3 US qt, 0.3 Imp qt}

OIL COOLER

PREPARATION
SST

<p>49 G014 001</p> <p>Wrench, oil filter</p>		<p>For removal / installation of oil filter</p>
--	---	---

D2

REMOVAL / INSTALLATION

1. Disconnect the negative battery cable.
2. Drain the engine coolant. (Refer to section E2.)
3. Remove in the order shown in the figure.
4. Install in the reverse order of removal.

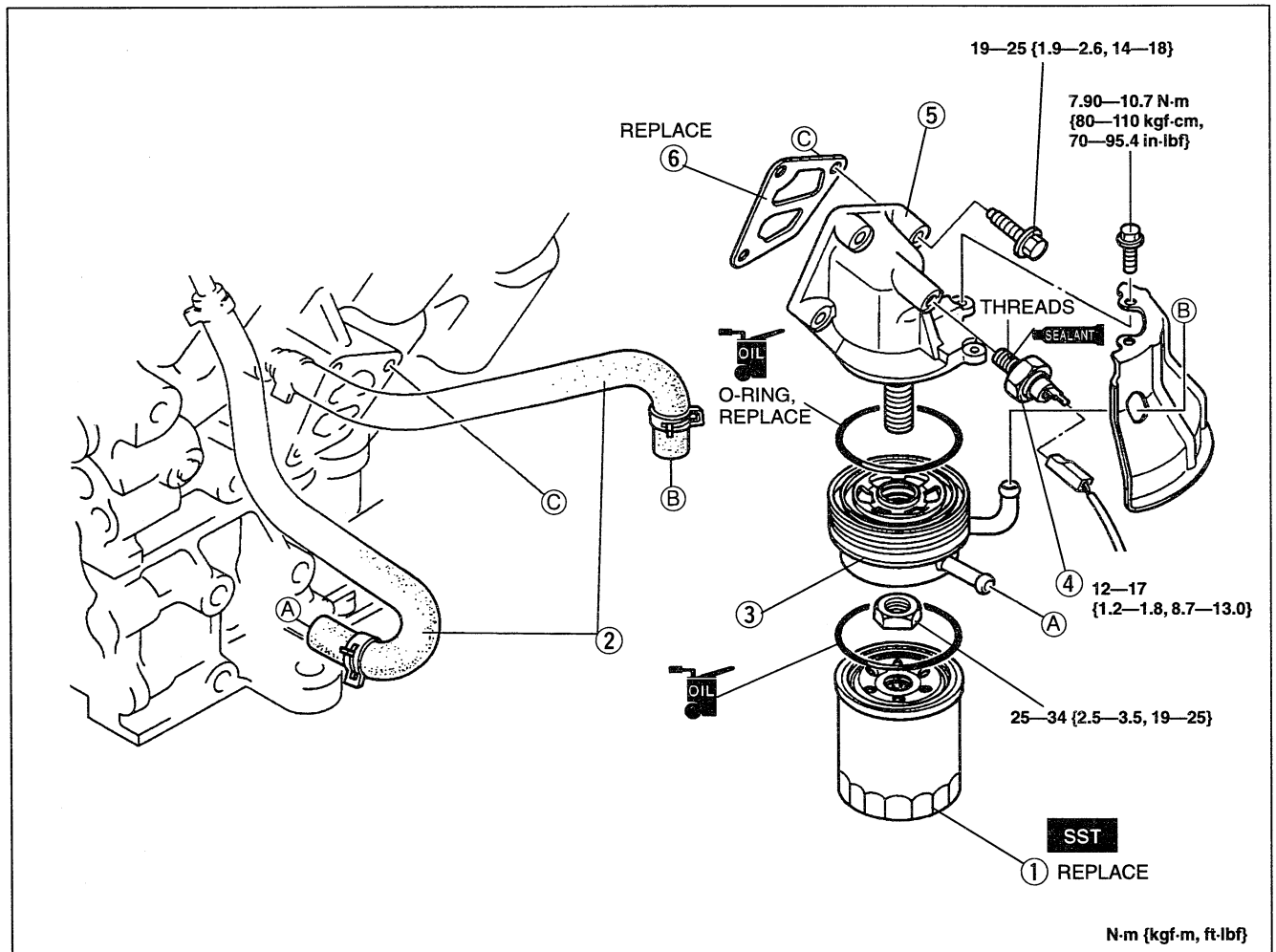

- | | |
|--|---|
| <ol style="list-style-type: none"> 1. Oil filter
Replacement page D2-6 2. Oil cooler hose 3. Oil cooler | <ol style="list-style-type: none"> 4. Oil pressure switch 5. Oil filter body 6. Gasket |
|--|---|

Steps After Installation

1. Fill with the specified amount and type of engine coolant. (Refer to section E2.)
2. Check for leaks.

OIL PAN

REMOVAL / INSTALLATION

1. Disconnect the negative battery cable.
2. Drain the engine oil. (Refer to page D2-5.)
3. Remove in the order shown in the figure, referring to **Removal Note**.
4. Install in the reverse order of removal, referring to **Installation Note**.

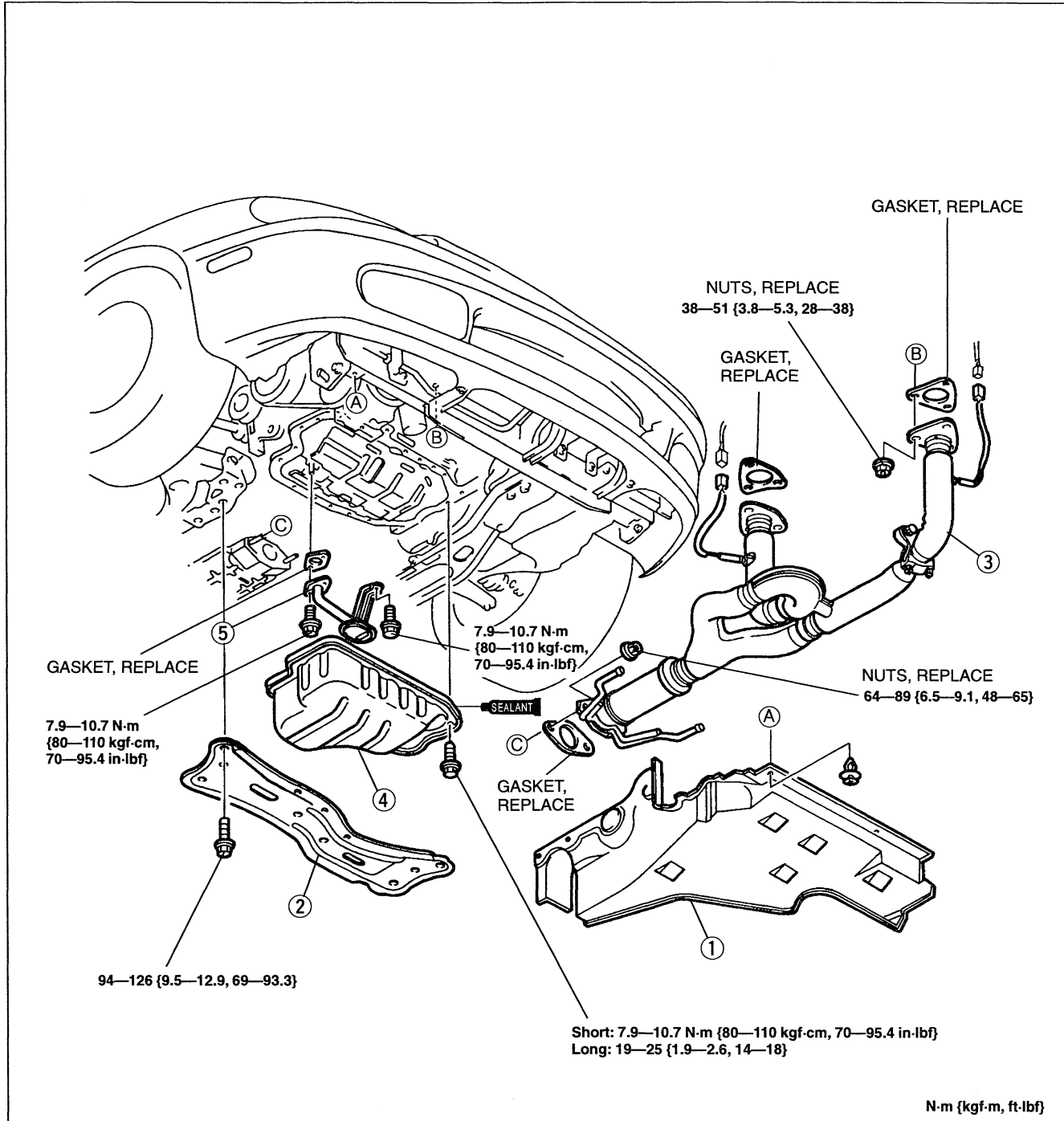

1. Splash shield
2. Transverse member
3. Front exhaust pipe

4. Oil pan
Removal Note page D2-9
Inspection page D2-9
Installation Note page D2-9
5. Oil strainer

Removal Note**Oil pan**

1. Remove the oil pan mounting bolts.

Caution

- Pry tools can easily scratch the lower cylinder block and oil pan contact surfaces. Prying off the oil pan can also easily bend the oil pan flange. Refer to the following instructions before removing the oil pan.

D2

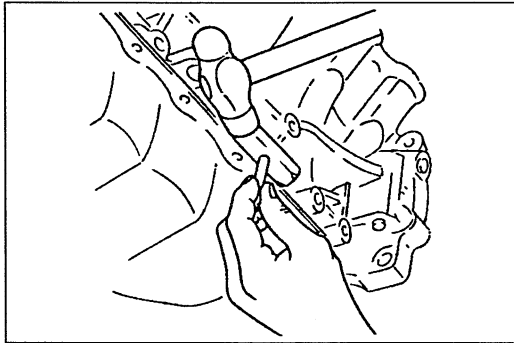

2. Separate the oil pan from the lower cylinder block by using a scraper or a separator tool.
3. Remove the oil pan.

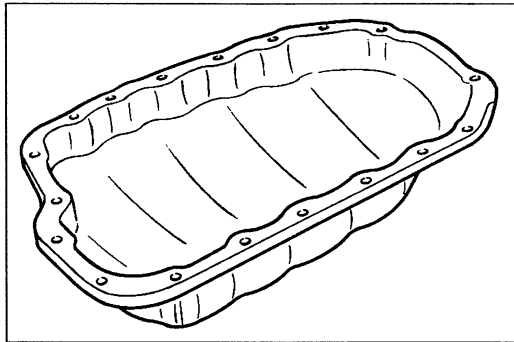
**INSPECTION****Oil Pan**

Visually check for cracks, deformation and damage. Repair or replace if necessary.

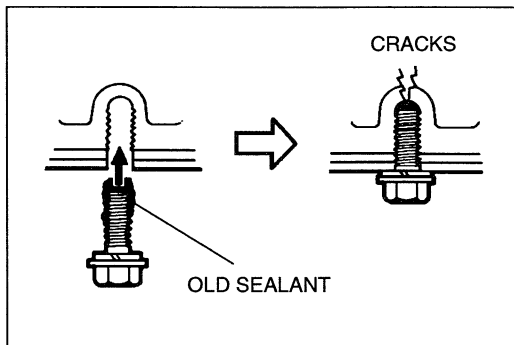
**Installation Note****Oil pan****Caution**

- If the bolts are reused, remove the old sealant from the bolt threads. Tightening a bolt that has old sealant on it can cause thread damage.

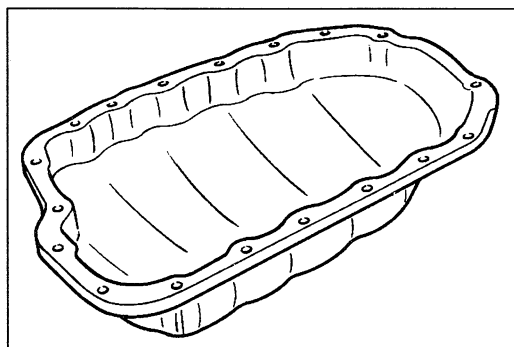

1. Remove all foreign material from the contact surfaces.

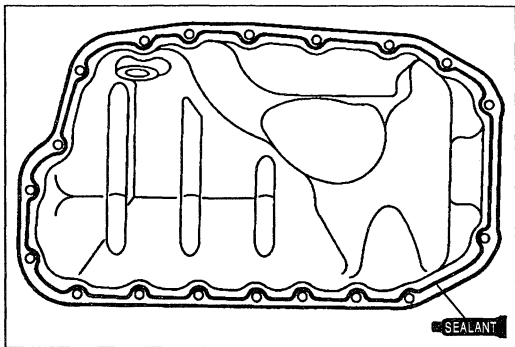

2. Apply silicone sealant to the oil pan flange as shown.

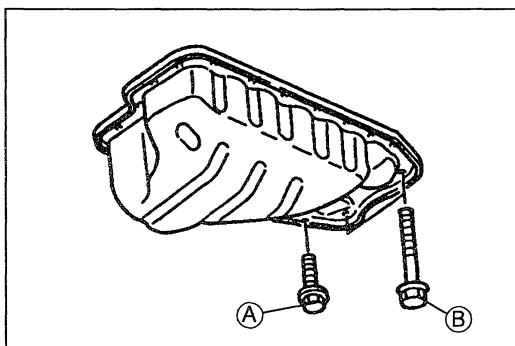

3. Install the oil pan within five minutes of applying the sealant.

Tightening torque

Ⓐ: 7.9—10.7 N·m {80—110 kgf·cm, 70—95.4 in·lb}

Ⓑ: 19—25 N·m {1.9—2.6 kgf·m, 14—18 ft·lb}

Steps After Installation

1. Fill with the specified amount and type of engine oil. (Refer to page D2-5.)
2. Connect the negative battery cable.
3. Start the engine and check for leaks.
4. Check the oil level and add oil if necessary.

OIL PUMP

PREPARATION
SST

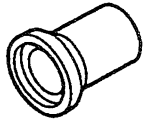
<p>49 H010 401</p> <p>Installer, oil seal</p>		<p>For installation of front oil seal</p>
---	---	---

DISASSEMBLY / ASSEMBLY

1. Disassemble in the order shown in the figure, referring to **Disassembly Note**.
2. Assemble in the reverse order of disassembly, referring to **Assembly Note**.

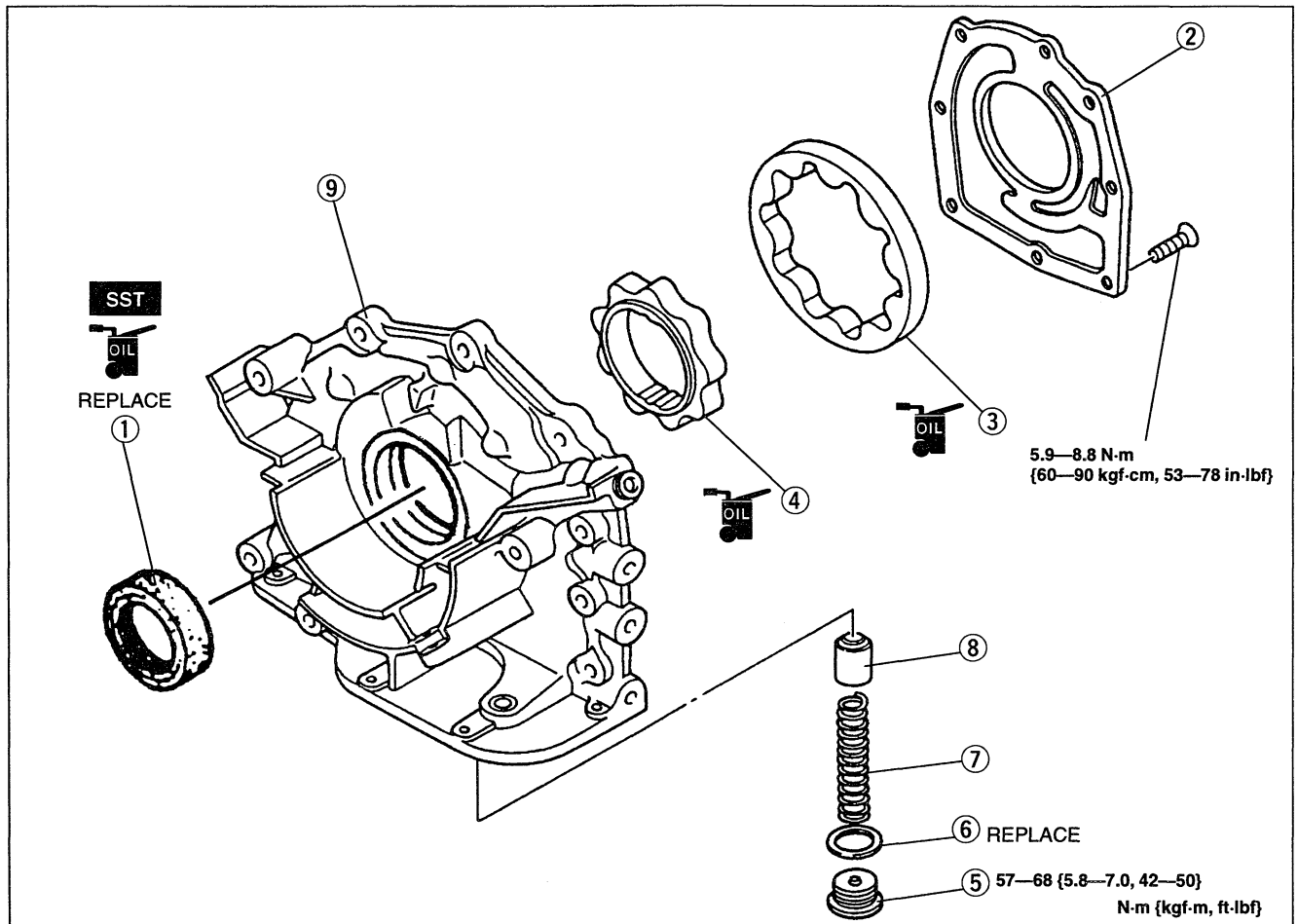

- | | |
|---|--|
| <ol style="list-style-type: none"> 1. Oil seal
Disassembly Note page D2-12
Assembly Note page D2-13 2. Pump cover
Disassembly Note page D2-12
Assembly Note page D2-13 3. Outer rotor
Inspection page D2-12
Assembly Note page D2-13 | <ol style="list-style-type: none"> 4. Inner rotor
Inspection page D2-12
Assembly Note page D2-13 5. Blind plug 6. Spring seat 7. Pressure spring
Inspection page D2-12 8. Control plunger 9. Pump body |
|---|--|

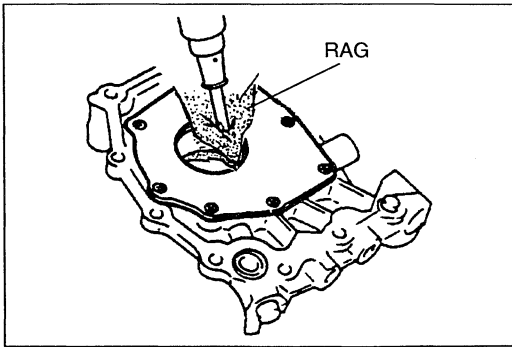
**Disassembly Note****Oil seal**

Remove the oil seal with a screwdriver protected with a rag.

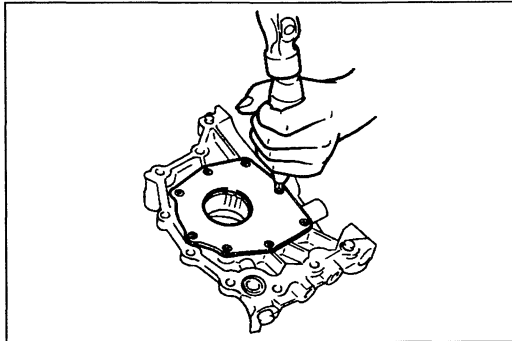
**Pump cover**

1. Remove the pump cover mounting bolts with an impact screwdriver.
2. Remove the pump cover.

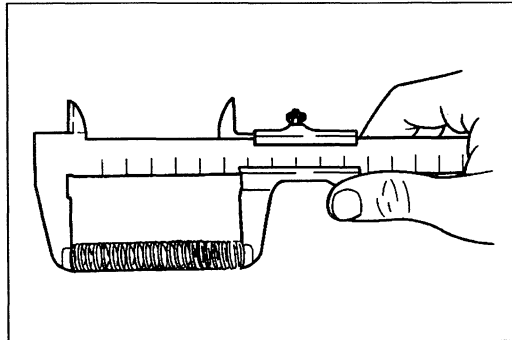
**INSPECTION****Pressure Spring**

1. Inspect the spring for weakness and damage.
2. Measure the spring free length. Replace the spring if necessary.

Free length: 46.79 mm {1.842 in}

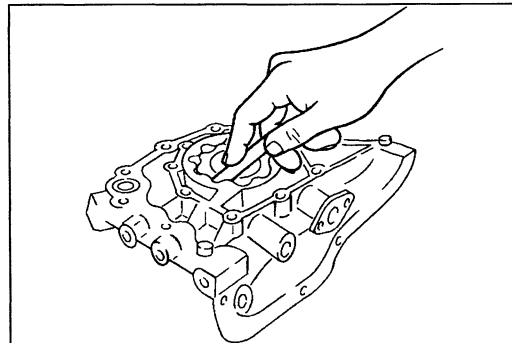
**Rotor Clearance**

Measure the following clearances. Replace the rotor if necessary.

Inner rotor-to-tooth tip clearance:

0.02—0.18 mm {0.0008—0.0070 in}

Maximum: 0.20 mm {0.0079 in}

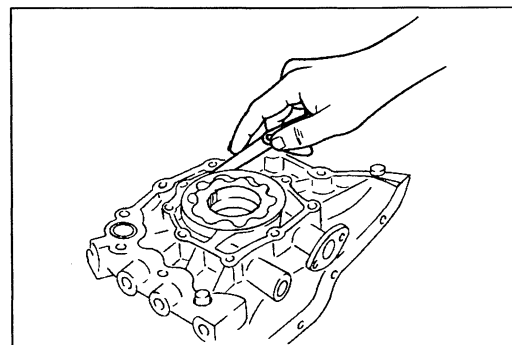
**Outer rotor-to-pump body clearance:**

0.113—0.186 mm {0.0045—0.0073 in}

Maximum: 0.22 mm {0.0087 in}

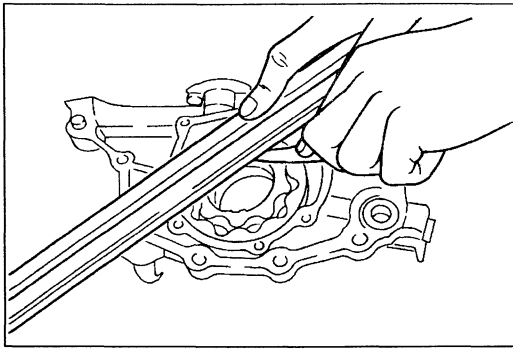

Side clearance: 0.03—0.09mm {0.0012—0.0035 in}
Maximum: 0.13mm {0.0051 in}

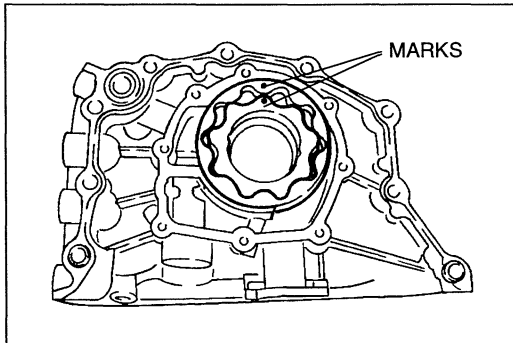

Assembly Note

Inner and outer rotor

1. Apply clean engine oil to the friction surface of the pump body and the rotors.
2. Install the inner and outer rotors into the oil pump body with the marks aligned as shown.

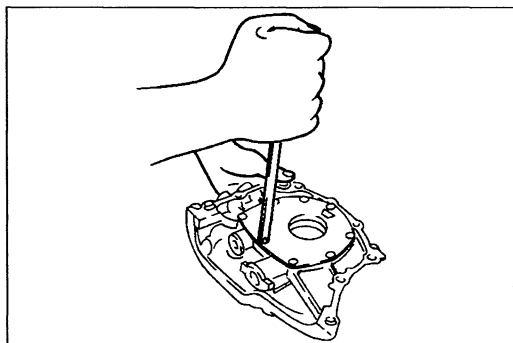

Pump cover

1. Install the pump cover.

Tightening torque:

5.9—8.8 N·m {60—90 kgf·cm, 53—78 in·lbf}

2. Verify that the oil pump rotates smoothly when turned by hand.

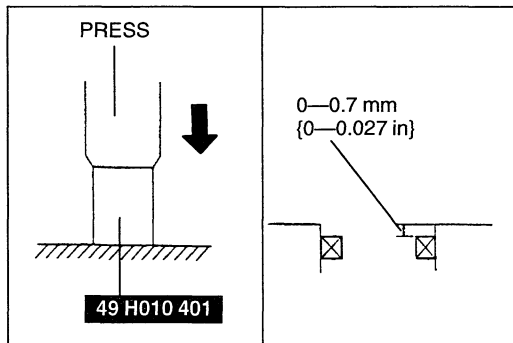

Oil seal

1. Apply clean engine oil to the new oil seal.
2. Install the oil seal into the oil pump body by hand.
3. Press the oil seal into the oil pump body by using the SST.