

Before beginning any service procedure, refer to section S of the 1996 626/MX-6 Body Electrical Troubleshooting Manual for air bag system service warnings.

# COOLING SYSTEM (FS)

<b>INDEX</b> .....	E1- 2
<b>OUTLINE</b> .....	E1- 3
SPECIFICATIONS .....	E1- 3
<b>TROUBLESHOOTING GUIDE</b> .....	E1- 3
<b>ENGINE COOLANT</b> .....	E1- 4
PREPARATION .....	E1- 4
INSPECTION .....	E1- 4
REPLACEMENT .....	E1- 5
<b>RADIATOR CAP</b> .....	E1- 7
PREPARATION .....	E1- 7
INSPECTION .....	E1- 7
<b>RADIATOR</b> .....	E1- 8
REMOVAL / INSTALLATION .....	E1- 8
INSPECTION .....	E1- 8
<b>THERMOSTAT</b> .....	E1- 9
REMOVAL / INSTALLATION .....	E1- 9
INSPECTION .....	E1- 9
<b>WATER PUMP</b> .....	E1-11
REMOVAL / INSTALLATION .....	E1-11
<b>COOLING FAN MOTOR</b> .....	E1-12
INSPECTION .....	E1-12
REPLACEMENT .....	E1-13
<b>COOLING FAN RELAY</b> .....	E1-14
REMOVAL .....	E1-14
INSPECTION .....	E1-14

## INDEX

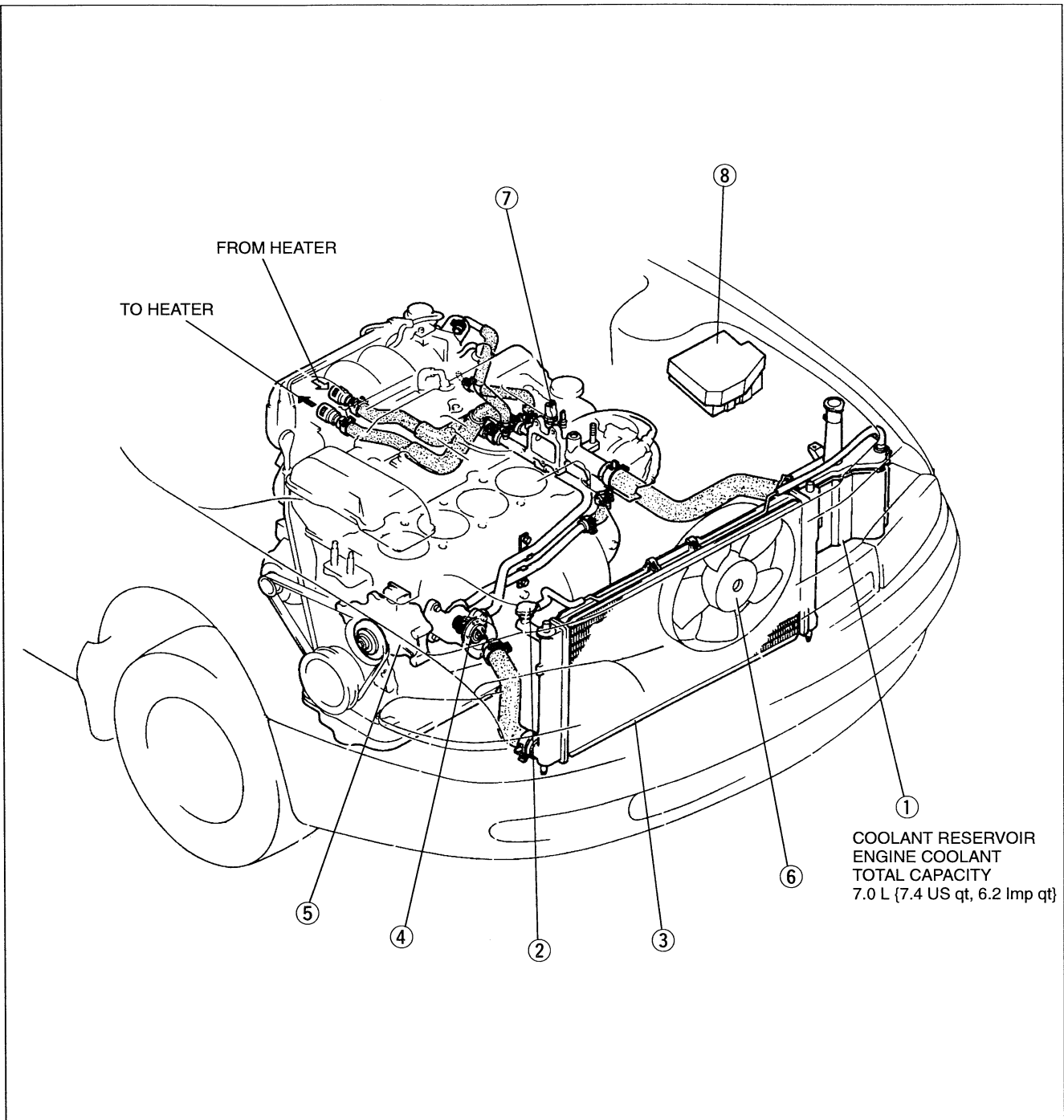

- |                                      |                 |  |  |
|--------------------------------------|-----------------|--|--|
| 1. Engine coolant                    |                 |  |  |
| Inspection .....                     | page E1-4       |  |  |
| Replacement .....                    | page E1-5       |  |  |
| 2. Radiator cap                      |                 |  |  |
| Inspection .....                     | page E1-7       |  |  |
| 3. Radiator                          |                 |  |  |
| Removal / Inspection /               |                 |  |  |
| Installation .....                   | page E1-8       |  |  |
| 4. Thermostat                        |                 |  |  |
| Removal / Inspection /               |                 |  |  |
| Installation .....                   | page E1-9       |  |  |
| 5. Water pump                        |                 |  |  |
| Removal / Installation .....         | page E1-11      |  |  |
| 6. Cooling fan motor                 |                 |  |  |
| Inspection .....                     | page E1-12      |  |  |
| Replacement .....                    | page E1-13      |  |  |
| 7. Engine coolant temperature sensor |                 |  |  |
| Removal / Inspection / .. MTX:       | section F1      |  |  |
| Installation .....                   | ATX: section F3 |  |  |
| 8. Cooling fan relay                 |                 |  |  |
| Removal .....                        | page E1-14      |  |  |
| Inspection .....                     | page E1-14      |  |  |

OUTLINE

SPECIFICATIONS

Item		Engine	FS	
Cooling system			Water-cooled, forced circulation	
Coolant capacity		L {US qt, Imp qt}	7.0 {7.4, 6.2}	
Water pump	Type		Centrifugal, V-ribbed belt-driven	
	Water seal		Unified mechanical seal	
Thermostat	Type		Wax, bottom-bypass	
	Opening temperature	°C {°F}	80—84 {176—183}	
	Full-open temperature	°C {°F}	95 {203}	
	Full-open lift	mm {in}	8.5 {0.33}min.	
Radiator	Type		Corrugated fin	
	Cap valve opening pressure	kPa {kgf/cm <sup>2</sup> , psi}	94—122 {0.95—1.25, 13.6—17.7}	
Cooling fan	Type		Electric	
	Blade	Outer diameter	mm {in}	340 {13.4}
		Number		4
	Motor	Current	A	5.6—7.6

E1

TROUBLESHOOTING GUIDE

Problem	Possible Cause	Action	Page
Overheating	Coolant level insufficient	Add	E1- 4
	Coolant leakage	Repair or replace	—
	Radiator fins clogged	Repair	E1- 8
	Radiator cap malfunction	Replace	E1- 7
	Cooling fan malfunction	Replace	E1-12
	Thermostat malfunction	Replace	E1- 9
	Water passage clogged	Clean	E1- 4
	Water pump malfunction	Replace	E1-11
Corrosion	Impurities in coolant	Replace	E1- 5

## ENGINE COOLANT

## PREPARATION

## SST

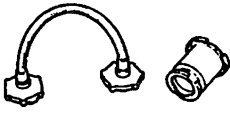
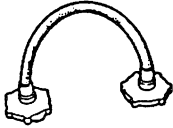
<p>49 9200 145</p> <p>Adapter set, radiator cap tester</p> 	<p>For inspection of cooling system</p>	<p>49 9200 146</p> <p>Adapter A (Part of 49 9200 145)</p> 	<p>For inspection of cooling system</p>
--	---	--	---

## INSPECTION

## Warning

- Removing the radiator cap or the radiator drain plug while the engine is running, or when the engine and radiator are hot is dangerous. Scalding coolant and steam may shoot out and cause serious injury. It may also damage the engine and cooling system. Turn off the engine and wait until it is cool. Even then, be very careful when removing the cap. Wrap a thick cloth around it and slowly turn it counterclockwise to the first stop. Step back while the pressure escapes. When you're sure all the pressure is gone, press down on the cap — still using a cloth — turn it, and remove it.

## Coolant Level (Engine cold)

1. Verify that the coolant level is at the filler neck.
2. Verify that the coolant level on the coolant dipstick is between the F and L marks.
3. Add coolant if necessary.

## Note

- The distance between the L and F marks on the dipstick represents 0.55 L {0.58 US qt, 0.48 Imp qt}.

## Coolant Quality

1. Verify that there is no buildup of rust or scale around the radiator cap and filler neck.
2. Verify that the coolant is free of oil. Replace the coolant if necessary.

## Coolant Leakage

1. Connect a radiator tester and the SST to the radiator filler neck.
2. Apply 123 kPa {1.25 kgf/cm<sup>2</sup>, 17.8 psi} pressure to the system.
3. Verify that the pressure is held. If not, check for coolant leakage.

## Caution

- Applying more than 123 kPa {1.25 kgf/cm<sup>2</sup>, 17.8 psi} can damage the hoses, fittings and other components, and cause leaks.

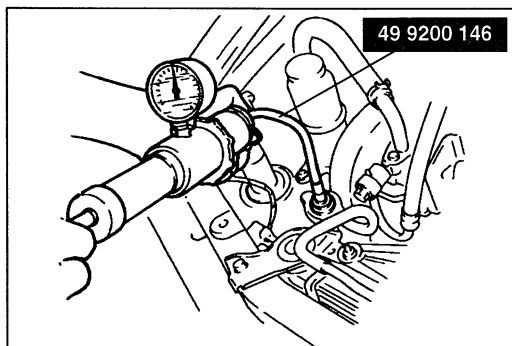
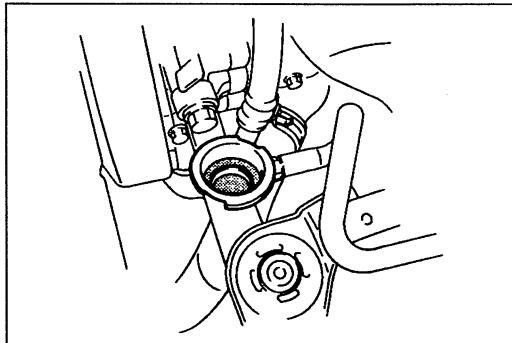
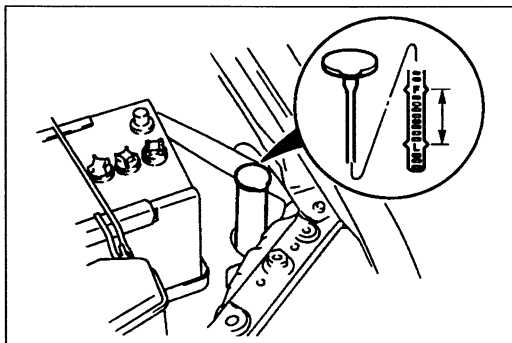

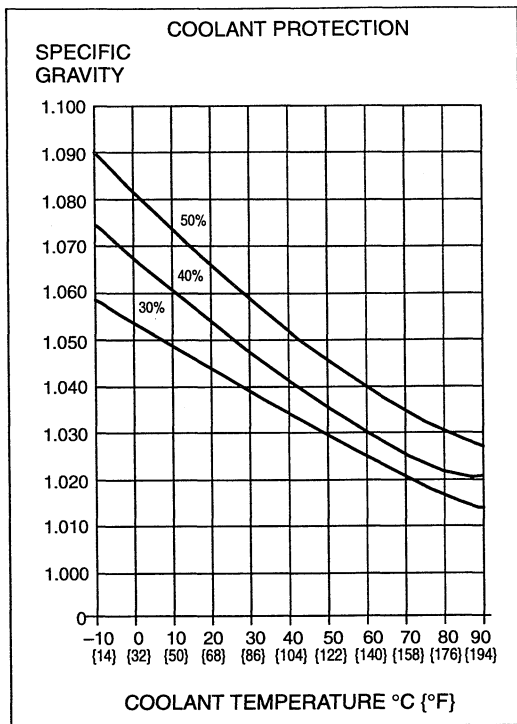

Coolant Protection

Caution

- The engine has aluminum parts that can be damaged by alcohol or methanol antifreeze. Do not use alcohol or methanol in the cooling system. Use only ethylene-glycol-based coolant.
- Use only soft (demineralized) water in the coolant mixture. Water that contains minerals will cut down on the coolant's effectiveness.

E1

1. Measure the coolant temperature and specific gravity with a thermometer and a hydrometer.
2. Determine the coolant protection by referring to the graph shown.
3. If the coolant protection is not proper, add water or coolant as necessary.

Antifreeze solution mixture percentage

Coolant protection	Volume percentage		Gravity at 20°C {68°F}
	Water	Coolant	
Above -16°C {3°F}	65	35	1.054
Above -26°C {-15°F}	55	45	1.066
Above -40°C {-40°F}	45	55	1.078

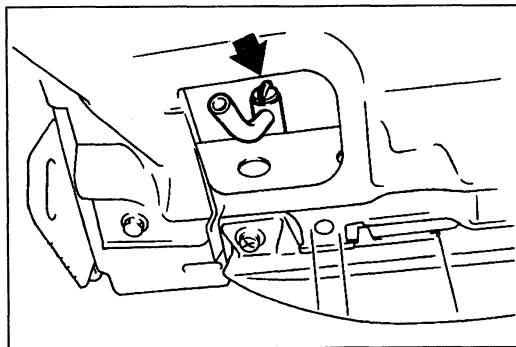

REPLACEMENT

Draining

Warning

- Removing the radiator cap or the radiator drain plug while the engine is running, or when the engine and radiator are hot is dangerous. Scalding coolant and steam may shoot out and cause serious injury. It may also damage the engine and cooling system. Turn off the engine and wait until it is cool. Even then, be very careful when removing the cap. Wrap a thick cloth around it and slowly turn it counterclockwise to the first stop. Step back while the pressure escapes. When you're sure all the pressure is gone, press down on the cap — still using a cloth — turn it, and remove it.

1. Remove the radiator cap and loosen the radiator drain plug.
2. Drain the coolant into a container.
3. Flush the cooling system with water until all traces of color are gone.
4. Let the system drain completely.
5. Tighten the drain plug.

**Refilling**

Use the proper amount and mixture of ethylene-glycol based coolant. (Refer to Coolant Protection, page E1-5.)

1. Slowly pour the coolant into the radiator up to the coolant filler port.

**Filling pace: 1.0 L {1.1 US qt, 0.9 Imp qt}/min. max.**

2. Fill the coolant reservoir up to the F mark.
3. Fully install the radiator cap.
4. Start the engine and let it idle until it warms up.
5. If the temperature increases beyond normal, there is excessive air in the system. Stop the engine and allow it to cool; then repeat steps 1—3.
6. Run the engine at 2,200—2,800 rpm for five minutes.
7. Stop the engine and allow it to cool.
8. Repeat steps 1—7; then go to step 9.

**Warning**

- **Removing the radiator cap or the radiator drain plug while the engine is running, or when the engine and radiator are hot is dangerous. Scalding coolant and steam may shoot out and cause serious injury. It may also damage the engine and cooling system.**



**Turn off the engine and wait until it is cool. Even then, be very careful when removing the cap. Wrap a thick cloth around it and slowly turn it counterclockwise to the first stop. Step back while the pressure escapes.**

**When you're sure all the pressure is gone, press down on the cap — still using a cloth — turn it, and remove it.**

9. Remove the radiator cap and verify that the engine coolant level is near the filler neck. If not, repeat steps 1—9.
10. Fill the reservoir up to the F mark.

## RADIATOR CAP

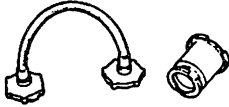
PREPARATION  
SST

<p>49 9200 145</p> <p>Adapter set, radiator cap tester</p> 	<p>For inspection of radiator cap</p>	<p>49 9200 147</p> <p>Adapter B (Part of 49 9200 145)</p> 	<p>For inspection of radiator cap</p>
--	---	---	---

E1

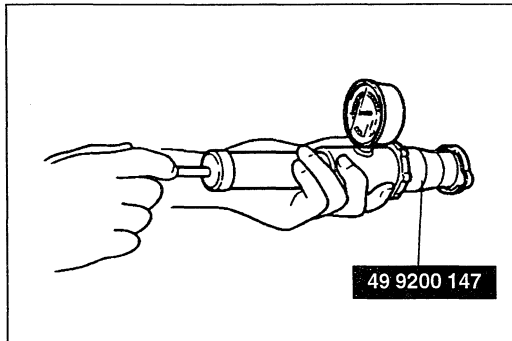
INSPECTION  
Radiator Cap Valve

## Warning

- Removing the radiator cap while the engine is running, or when the engine and radiator are hot is dangerous. Scalding coolant and steam may shoot out and cause serious injury. It may also damage the engine and cooling system. Turn off the engine and wait until it is cool. Even then, be very careful when removing the cap. Wrap a thick cloth around it and slowly turn it counterclockwise to the first stop. Step back while the pressure escapes.

When you're sure all the pressure is gone, press down on the cap — still using a cloth — turn it, and remove it.

1. Remove all foreign material (such as water residue) from between the radiator cap valve and the valve seat.
2. Attach the radiator cap to a radiator cap tester with the SST. Apply pressure gradually to **94—122 kPa {0.95—1.25 kgf/cm<sup>2</sup>, 13.6—17.7 psi}**.
3. Verify that the pressure is held for at least **10 seconds**.

## Negative Pressure Valve

1. Pull the negative pressure valve to open it. Verify that it closes completely when released.
2. Check for damage of the contact surfaces and for cracked and deformed seal packing.
3. Replace the radiator cap if necessary.

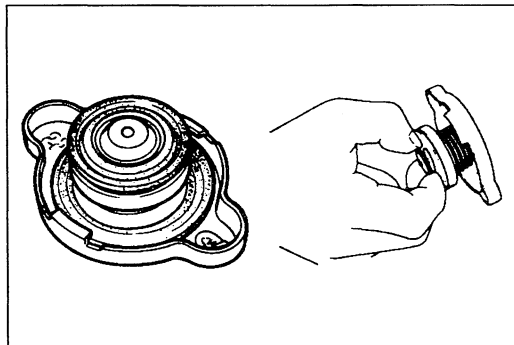

## RADIATOR

### REMOVAL / INSTALLATION

1. Disconnect the negative battery cable.
2. Drain the engine coolant. (Refer to page E1-5.)
3. Remove in the order shown in the figure.
4. Install in the reverse order of removal.

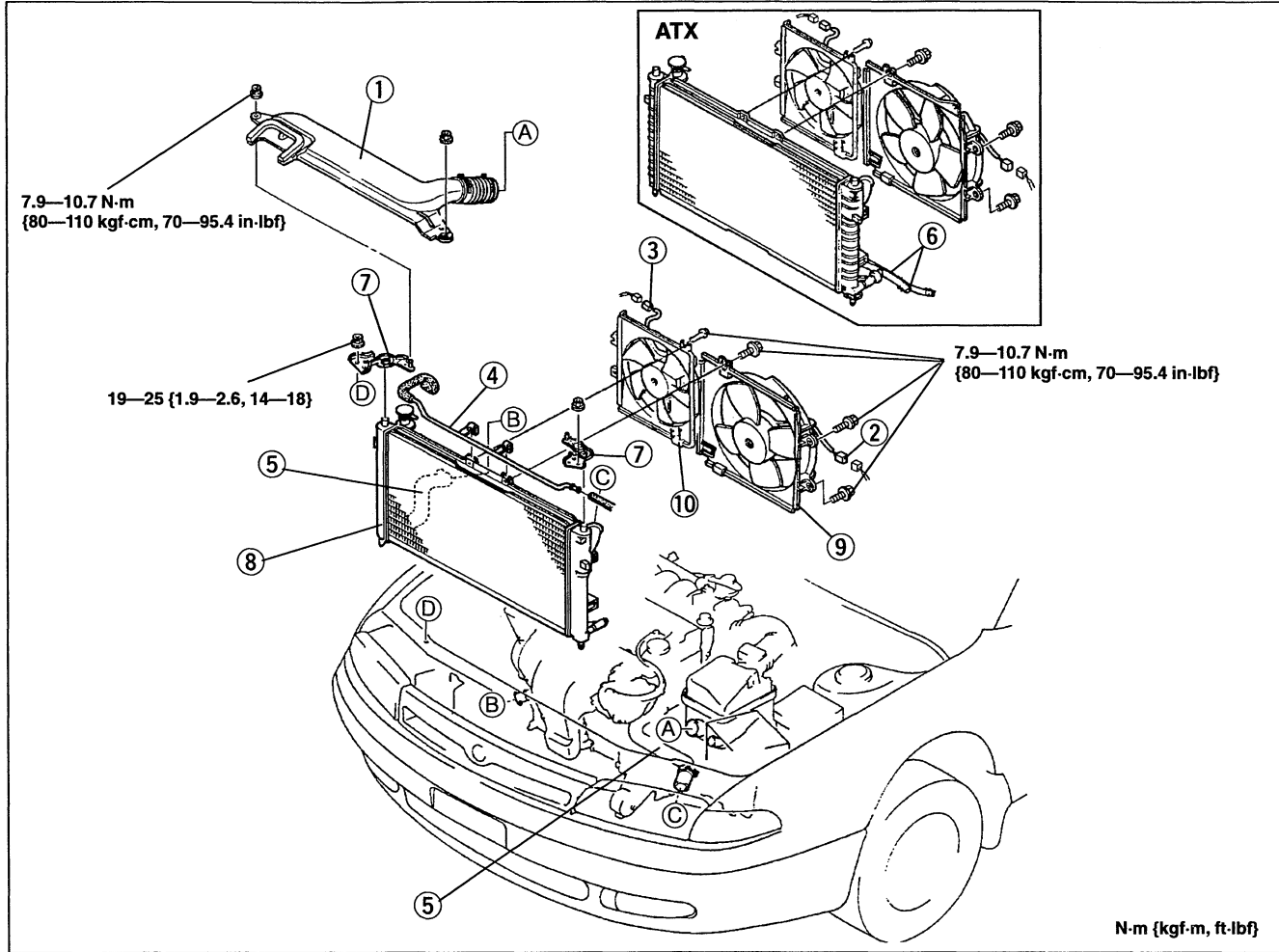

1. Fresh-air duct
2. Cooling fan motor connector
3. Condenser fan motor connector
4. Coolant reservoir pipe
5. Radiator hose (upper and lower)
6. Oil cooler hose (ATX)

7. Radiator bracket
8. Radiator  
Inspection ..... below
9. Cooling fan and radiator cowling assembly
10. Condenser fan and radiator cowling assembly

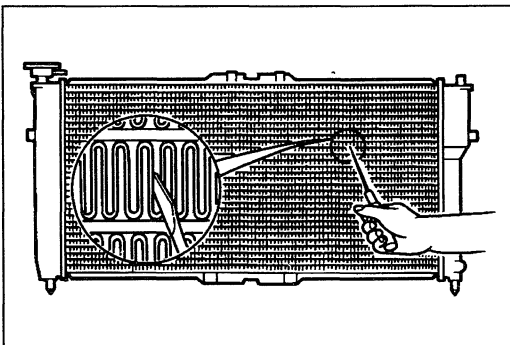

### INSPECTION

#### Radiator

Check for the following and repair or replace as necessary.

1. Cracks, damage, and water leakage.
2. Bent fins (Repair with a screwdriver.)
3. Distorted and bent radiator inlet and outlet.

#### Steps After Installation

1. Fill the radiator with the specified amount and type of engine coolant. (Refer to page E1-6.)
2. Check for leaks.



**THERMOSTAT**

**REMOVAL / INSTALLATION**

1. Disconnect the negative battery cable.
2. Drain the engine coolant. (Refer to page E1-5.)
3. Remove in the order shown in the figure.
4. Install in the reverse order of removal, referring to **Installation Note**.

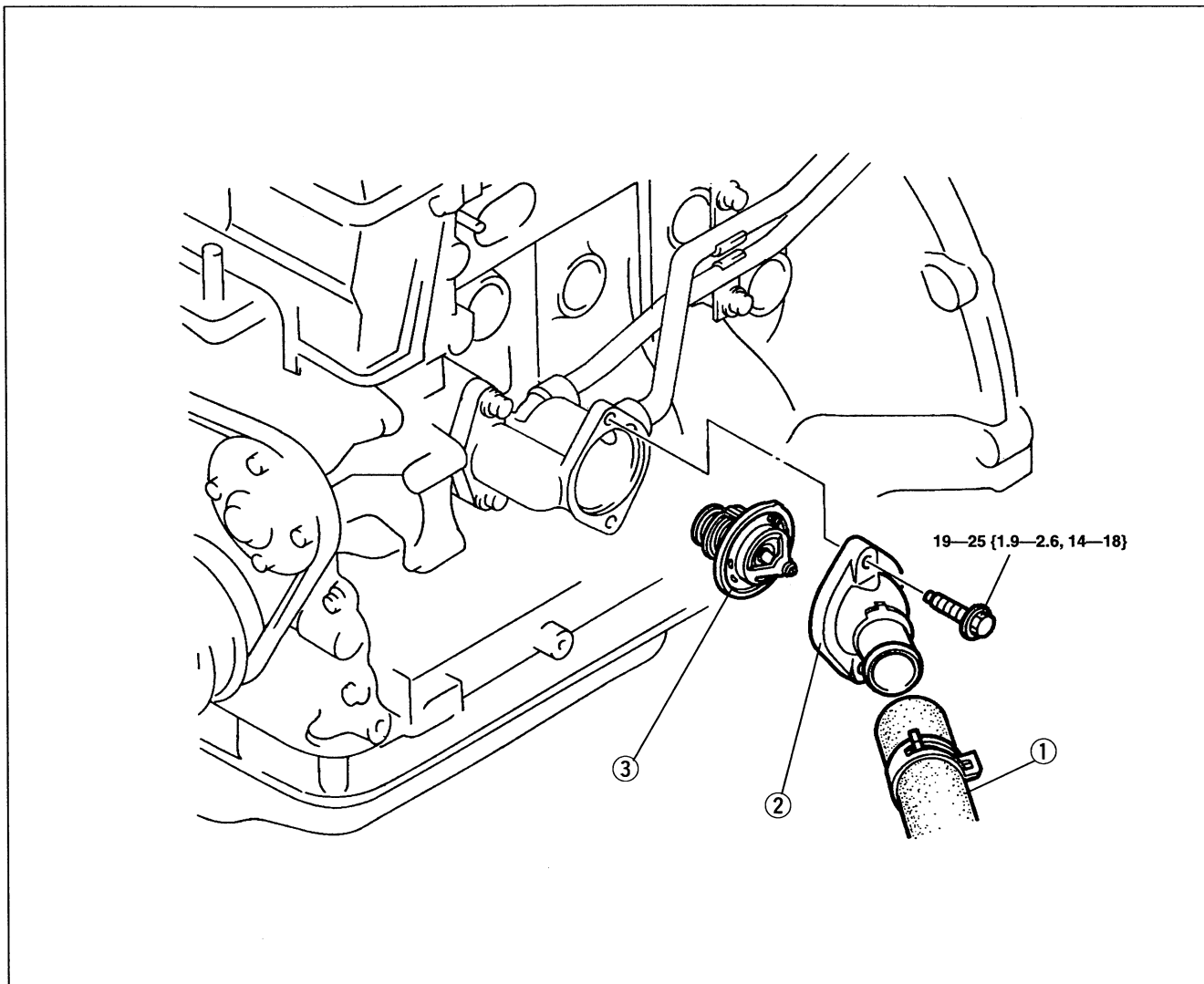

1. Radiator hose, lower
2. Thermostat cover

3. Thermostat  
 Inspection ..... below  
 Installation Note ..... page E1-10

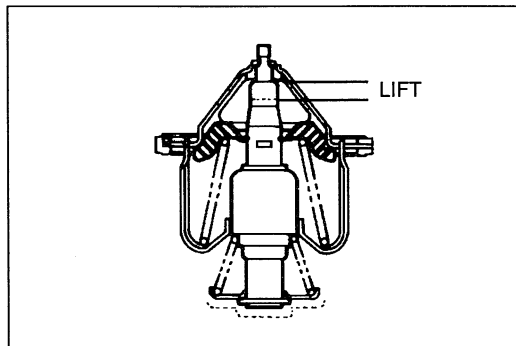

**INSPECTION**

**Thermostat**

1. Visually check that the thermostat valve is airtight.
2. Place the thermostat and a thermometer in water.
3. Heat the water and check the following.

**Initial-opening temperature: 80—84°C {176—183°F}**

**Full-open temperature: 95°C {203°F}**

**Full-open lift: 8.5mm {0.33 in} min.**

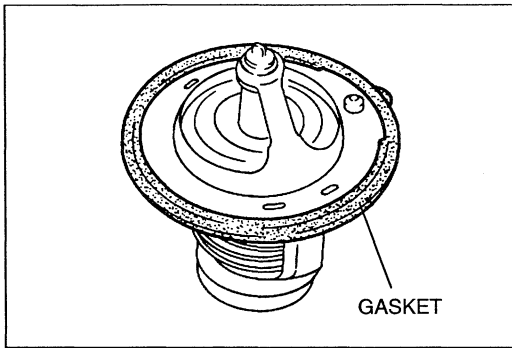

4. If the gasket of the thermostat is damaged, replace the thermostat assembly.

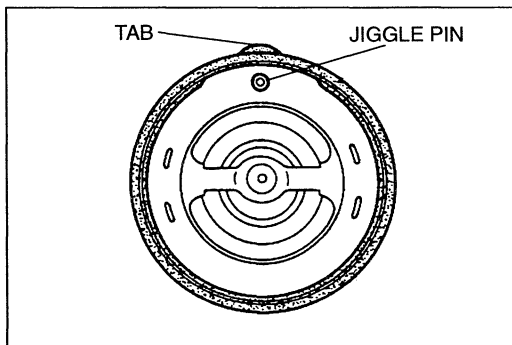

**Installation Note**  
**Thermostat**

1. Verify that the jiggle pin is aligned with the projection of the thermostat gasket as shown.

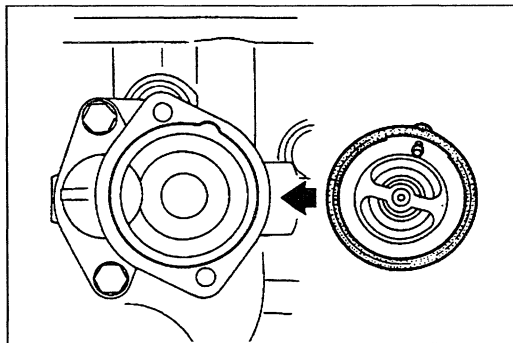

2. Install the thermostat and gasket into the thermostat housing, aligning the tab to the housing, as shown in the figure.

**Steps After Installation**

1. Fill the radiator with the specified amount and type of engine coolant. (Refer to page E1-6.)
2. Check for leaks.

WATER PUMP

REMOVAL / INSTALLATION

1. Disconnect the negative battery cable.
2. Drain the coolant. (Refer to page E1-5.)
3. Remove in the order shown in the figure.
4. Install in the reverse order of removal.

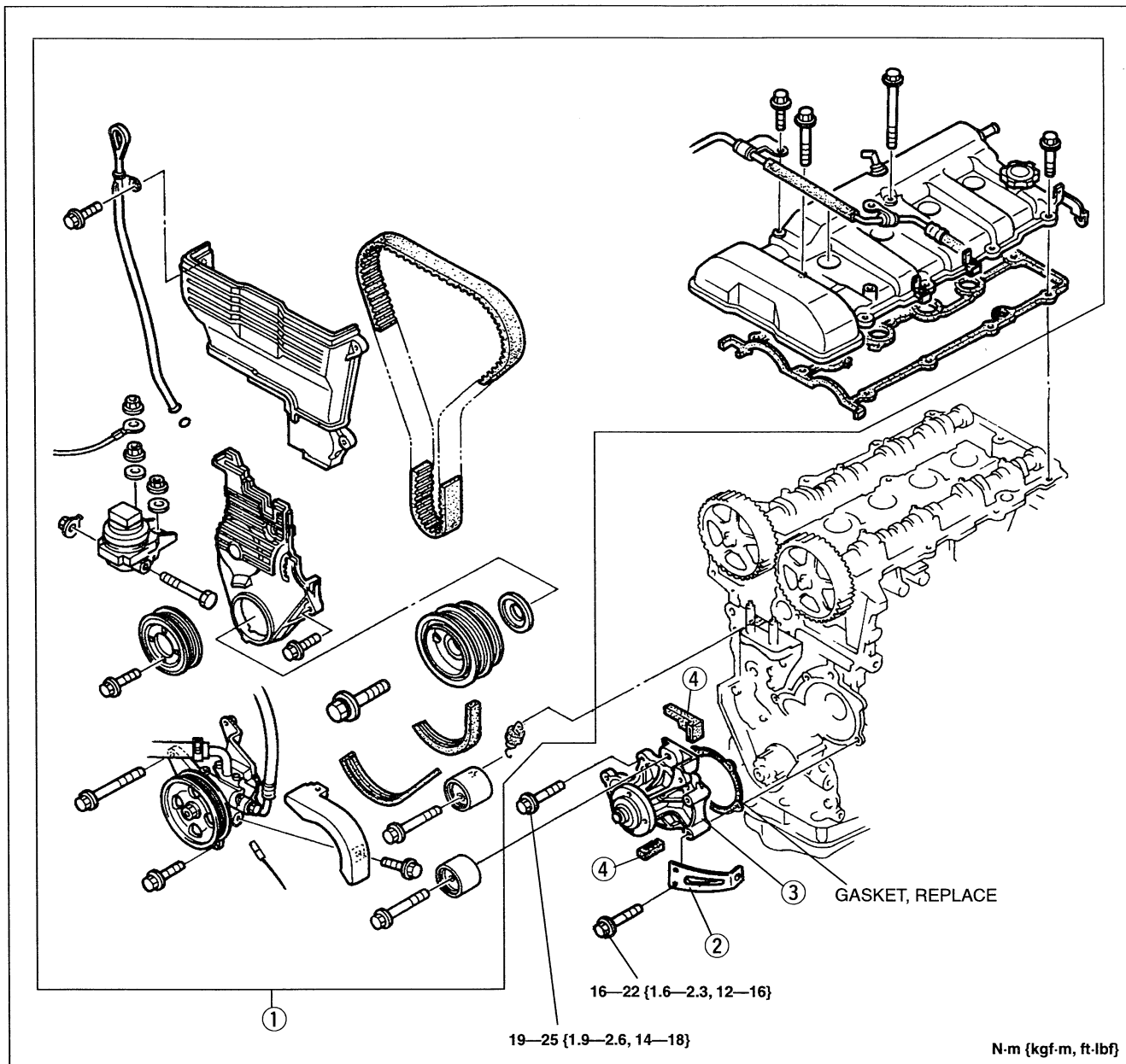

1. Timing belt  
Removal / Installation . . . . . section B1
2. P/S oil pump adjuster

3. Water pump assembly  
Inspect for cracks, damaged mounting surface, bearing condition, and leakage
4. Water pump rubber seal

Steps After Installation

1. Fill the radiator with the specified amount and type of engine coolant. (Refer to page E1-6.)
2. Check for leaks.

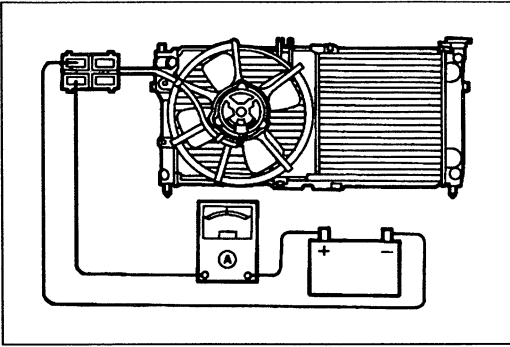

### COOLING FAN MOTOR

#### INSPECTION

1. Verify that the battery is fully charged.
2. Disconnect the cooling fan motor connector.
3. Connect battery positive voltage and an ammeter to the cooling fan motor connector.
4. Verify that current draw is as specified.

**Current: 5.6—7.6A**

5. If current is not within the specification or the cooling fan does not turn smoothly, replace the cooling fan motor.

**REPLACEMENT**

1. Disconnect the negative battery cable.
2. Remove in the order shown in the figure.
3. Install in the reverse order of removal.

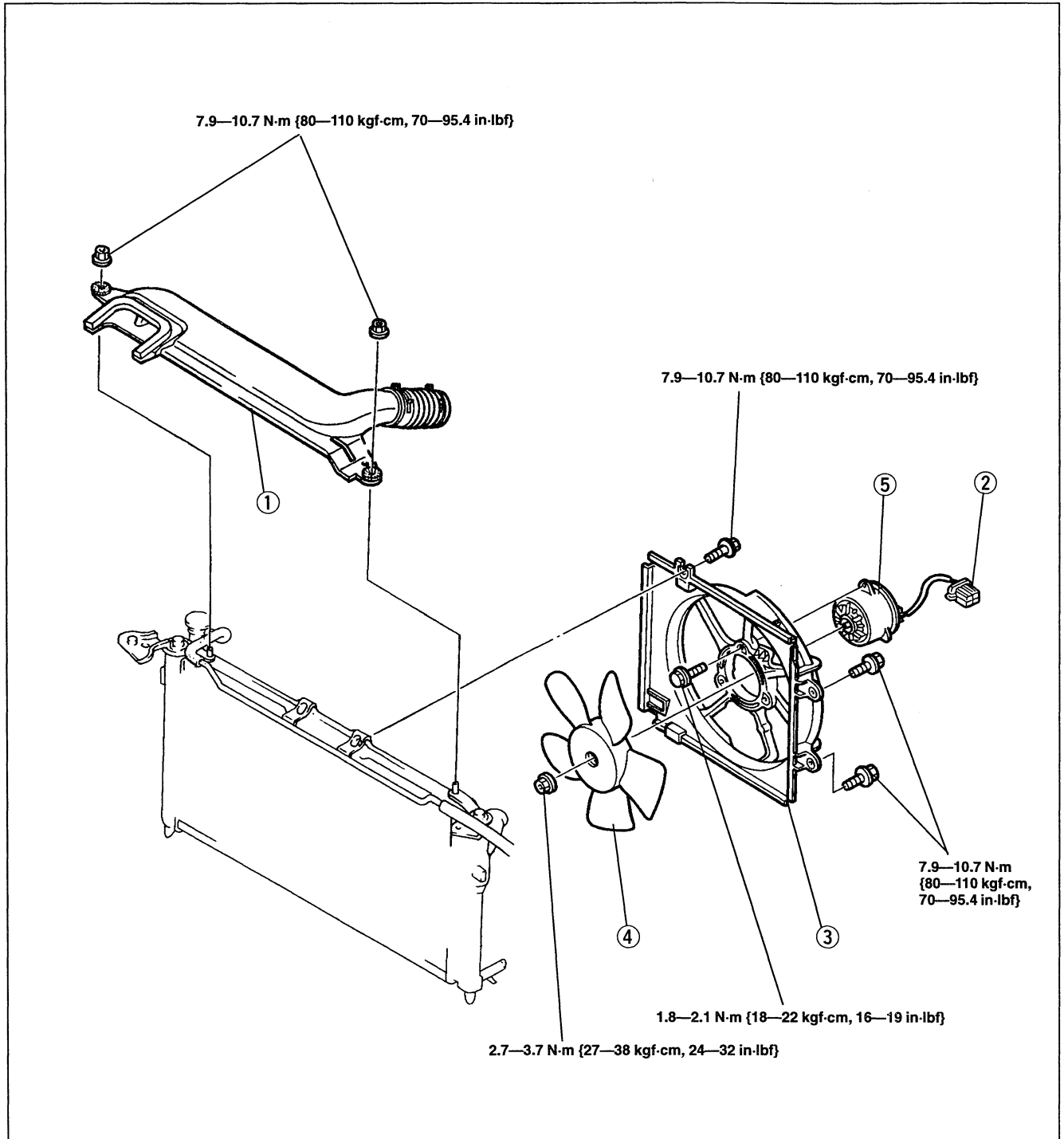

1. Fresh-air duct
2. Cooling fan motor connector
3. Radiator cowl

4. Cooling fan blade
5. Cooling fan motor

**Steps After Installation**

1. Fill the radiator with the specified amount and type of engine coolant. (Refer to page E1-6.)
2. Check for leaks.

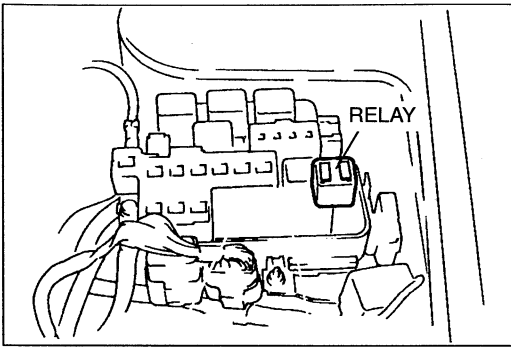

### COOLING FAN RELAY

#### REMOVAL

1. Disconnect the negative battery cable.
2. Remove the cooling fan relay shown in the figure.

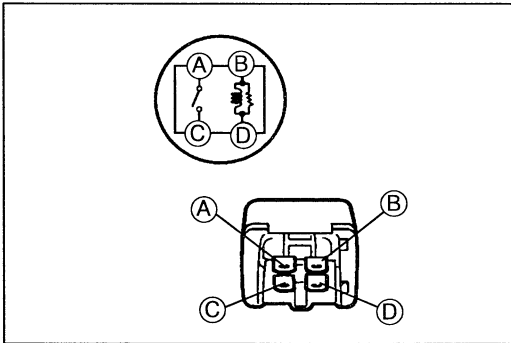

#### INSPECTION

1. Check continuity of the cooling fan relay as shown.

Terminal	Continuity
A—C	No
B—D	Yes

2. Apply battery positive voltage between terminals B and D. Check for continuity between terminals A and C.
3. If not as specified, replace the cooling fan relay.